

RWF BRON

V75-II PLOW OPERATOR'S MANUAL

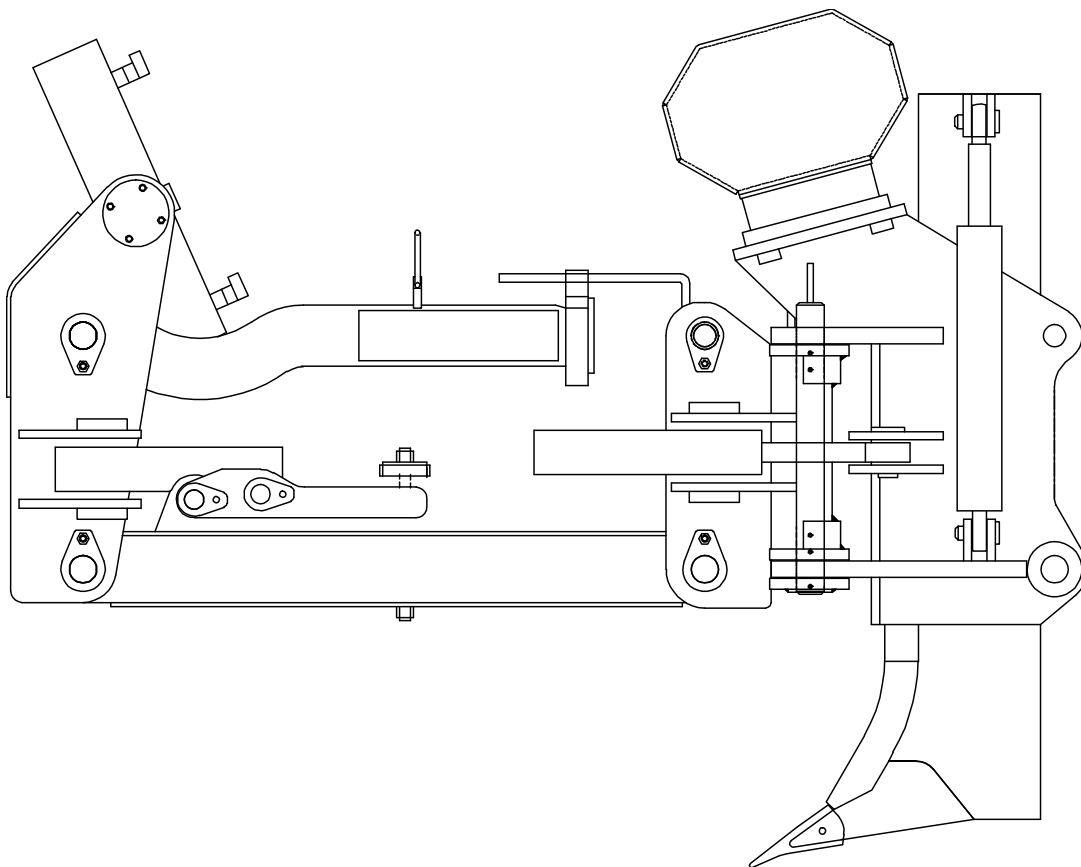

RWF INDUSTRIES

873 Devonshire Ave., Woodstock,

Ontario N4S 8Z4

Tel: (519) 421-0036

Toll Free: 1-800-263-1060

Fax: (519) 421-0028

Email: rwf@wwdc.com

TABLE OF CONTENTS

INTRODUCTION.....	1
 INTRODUCTION / WARNINGS.....	1.1
INSTALLATION.....	1.2-6
 PLOW ASSEMBLY TO TRACTOR.....	1.2
 DIRECTIONAL CONTROL VALVE / FLOW CONTROL / SHAKER MOTOR.....	1.3
 SHANK & CHUTE.....	1.4
 REEL CARRIER.....	1.4-5
 POWER REWIND.....	1.5
 SHAKER CONTROL CABLE / COOLER / REMOTE CONTROL LEVERS.....	1.6
HYDRAULIC HOSE SPECIFICATION GUIDE.....	1.7-8
PRE-OPERATION CHECKLIST.....	1.9
VIBRATORY PLOW OPERATION.....	1.9-10
LUBRICATION POINTS.....	1.10
WARRANTY.....	2

INTRODUCTION

This manual contains installation instructions, pre-operational checklist, operating procedures, parts and components for the BRON Vibratory Plows. Some items and procedures listed in this manual are for optional accessories that may not apply to the practical plow package purchased or the tractor it is mounted on.

WARNINGS

WARNING



DO NOT WELD ON THE SHANK OR LINKAGES. (They are made from heat-treated alloy steel)

WARNING



ALL HYDRAULIC LINES, VALVE, ETC. INSTALLED WITHIN THE TRACTOR CAB SHOULD HAVE GUARDS INSTALLED TO PROTECT THE OPERATOR IN CASE OF ANY HYDRAULIC OIL RUPTURES.

RWF INDUSTRIES RESERVES THE RIGHT TO MAKE IMPROVEMENTS IN DESIGN, MATERIAL AND/OR CHANGES IN SPECIFICATIONS AT ANY TIME WITHOUT INCURRING ANY OBLIGATION RELATED TO SUCH CHANGES.

INSTALLATION

Plow Assembly to Tractor

- A. Remove all attachments and studs / bolts from the rear of the transmission case.
- B. Remove all paint (on the tractor) from the area to be covered by the plow's backplate. Grind off all burrs and rough spots.
- C. Clean out tapped stud / bolt holes to remove any dirt or rust. If possible run a tap into the holes to remove any burrs, or foreign material in the bottom of the threads.
- D. Attach the plow's backplate to the housing using the correct length and diameter studs / bolts.
- E. Studs should be threaded into the full depth available in the housing.

NOTE

Seal any openings in the transmission that are covered by backplate with silicone seal. This is to prevent water contamination in the transmission.

- F. Hi-torque washers and Grade 8 nuts or equivalent should be used where required.
- G. Apply Loctite to studs, bolts and hole threads.
- H. Torque all studs, bolts and nuts according to the original tractor manufacturer's specifications.

The following torque chart may be used as an approximate guide.

Table 1 TORQUE CHART (guideline)

Diameter	DRY - NC	DRY - NF	LUB - NC	LUB - NF
$\frac{3}{4}$ "	370	415	200	225
$\frac{7}{8}$ "	600	660	330	360
1"	900	990	495	545
1 $\frac{1}{4}$ "	1800	1995	990	1095
1 $\frac{1}{2}$ "	3150	3550	1730	1950

NOTE

Some tractor installations may have a pinned connection between the tractor and the plow's backplate. For this attachment, the backplate will be designed for same. Dealer supplied pins will be required in lieu of mounting bolts and/or studs.

Directional Control Valve (Plow)

FIXED VOLUME	VARIABLE VOLUME
Main lift	
Front swing	
Rear swing	
Attitude	
Blade lift	
	Shaker
	Rewind

A separate section of the control valve is required for each hydraulic function of the plow.

The control valve is normally mounted on the front side of the main mast and is controlled by remote levers mounted on the right hand side of the operator. These levers are connected to the control valve with control cables.

The hydraulic hoses and fittings for the connection between the tractor and plow control valve are to be supplied by the installing dealer. Refer to hydraulic hose specification chart for hydraulic hose diameter sizing and specifications.

NOTE

On some tractors, a separate pump may be installed. In this case, the power beyond and tank are connected together and the return line runs directly back to the tank through a filter.

The return line should be connected near the bottom side of the tank and deflected away from the suction line.

An alternative is to go into the top of the tank with a standpipe, down to the bottom of the tank and deflect it away from the suction line.

Flow Control - Shaker Motor**Fixed Volume**

A flow control is provided to control the speed of the shaker motor. This valve is mounted on the top pivot plate of the backplate. Set flow control so that the flow to the shaker motor is a maximum of 18 G.P.M. Refer to the Hydraulic Schematic (located in the back of this book) for location and attachment of flow control and the proper hook up to your particular plow and tractor.

Variable Volume

The motor spool section control valve turns the shaker off and on. This section has a built in speed control that is adjusted with a twist cable.

Shaker Motor

The shaker motor drives the shaker box. The separate drain line provided on the motor must be connected directly back to the top of the hydraulic tank by the dealer. This line is a low-pressure drain and is not to have more than 25 PSI backpressure.

Shank & Chute

Shank

- A. Remove the rear pins and spacer bar from the blade holder.
- B. Slide shank into rear of blade holder.
- C. Install pins and spacer bar.
- D. For hydraulically adjustable shank, hook up rod end of cylinder to brackets at top of the shank and install pin and keeper bolt.
- E. Tighten threaded pins until the cylinder will not move the shank. Back off just enough to allow this cylinder to move the blade (This is for max shake transfer to shank).

Chute

- A. Pin lugs on front of chute to lugs on back of the shank with 1" bolts and lock nuts.

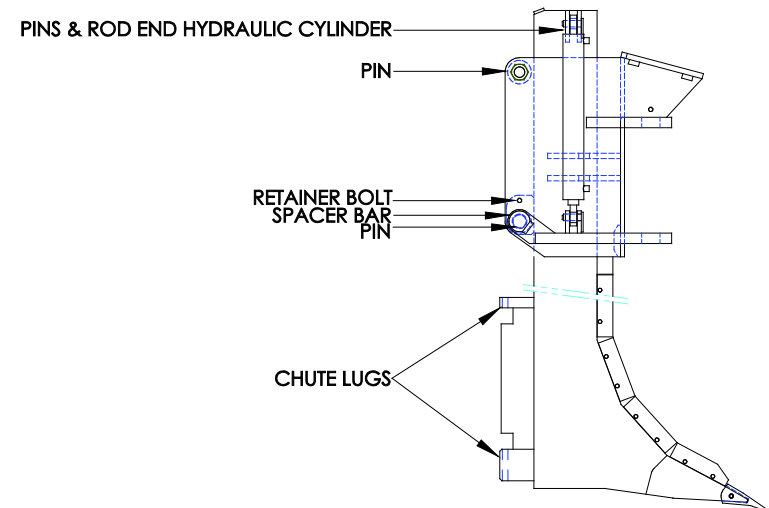

HYDRAULIC ADJUSTABLE BLADE AND HOLDER

Reel Carrier

Blade Mount

- A. From centre of blade length, measure 42" in each direction and mark same on the top leading edge of the blade.
- B. Place inner edge of outside mounting plates (item 3) at the 42" marks and tack weld.

NOTE

These plates are of a universal nature and may need trimming to match your blade profile.

- C. Place inside mounting plates 6 $\frac{1}{8}$ " from the respective outside mounting plates and tack weld.

NOTE

Ensure that these four mounting plates are in line with each other prior to tack welding.

- D. Tack weld the four gusset plates (Item 2).

- E. Attach the side frames (Item 1) to the mounting plates with pins (Item 6). Side frames should be 80" apart, outside edge to outside edge.
- F. Attach the arbour bar onto the ends of the side frame.
- G. Check that the side frames are square by measuring diagonally from points A to D and from C to B.
- H. Ensure that the centre line of the arbour is approximately 12" from ground level while blade is sitting on the ground.
- I. After ensuring that the side frames are square, tack weld the cross tubes (Item 4) as per diagram.
- J. Install corner gussets (Item 5) as indicated on the diagram and tack weld into position.
- K. Do final check that everything is square and correct. Weld all areas that have previously been tack welded.

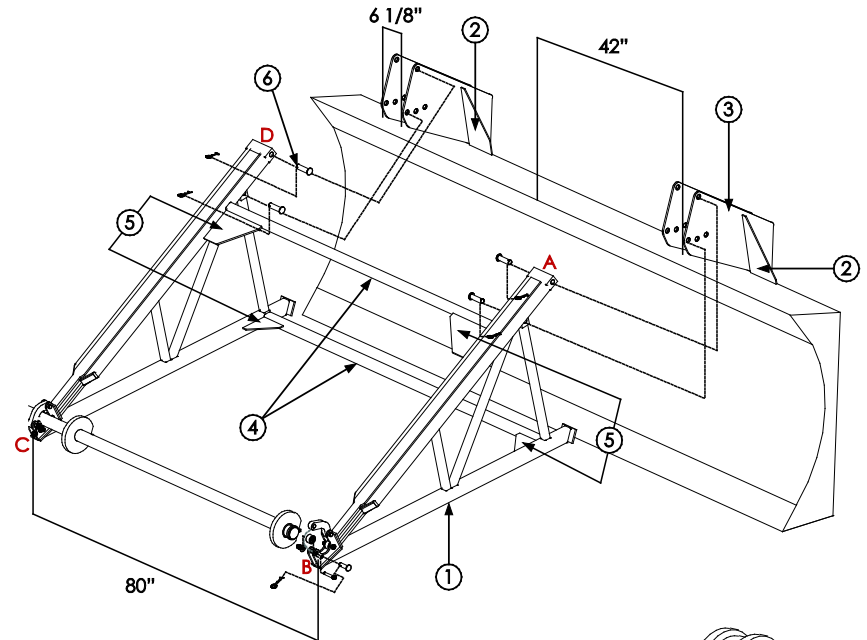

Frame Mount

- A. Clean hard nose area of tractor prior to mounting reel carrier.
- B. Attach mounting brackets as per drawing supplied with reel carrier. Bracket locations will vary depending on make and model of tractor.
- C. Tack weld brackets.
- D. Mount reel carrier to brackets and check for proper alignment and clearances.
- E. Complete welding all areas previously tack welded using 1/2" fillet welds.
- F. Check all hardware fasteners for tightness.

Power Rewind (Frame Mounted Reel Carrier Only)

- A. Bolt mounting brackets (Items 2 & 3 below). Inside dimension between brackets will be determined by the slide bar shaft (Item 6).
- B. Check alignment by installing the two slide bar shafts (Item 4 & 5).
- C. If alignment is correct, tighten the mounting bracket bolts.
- D. Remove the two shafts (Item 4 & 5) and insert the arm weldment (Item 1). Re-install the two shafts and attach r-clips.
- E. To obtain desired height positioning of the wheel, use adjustment pin assembly (Item 6).

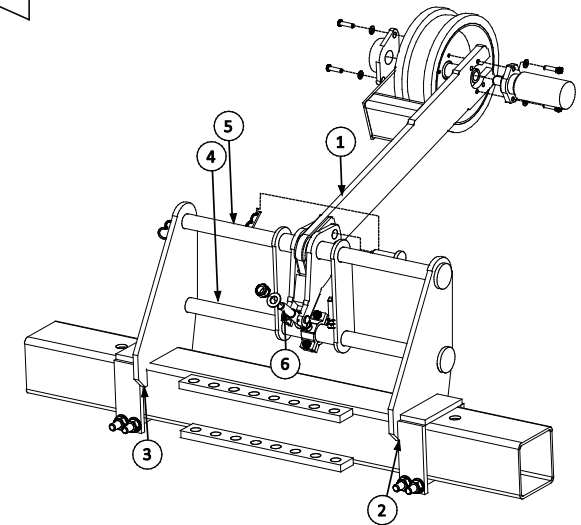

Shaker Control Cable

A control cable is provided to control the speed of the shaker motor. This cable is usually installed with the above levers.

Cooler

Fixed Volume

Return oil from the shaker motor and exhaust port (EX) of flow divider should go through the cooler before returning to the tank through filter.

Variable Volume

Return oil from the shaker motor should go through the cooler before returning to the tank through filter.

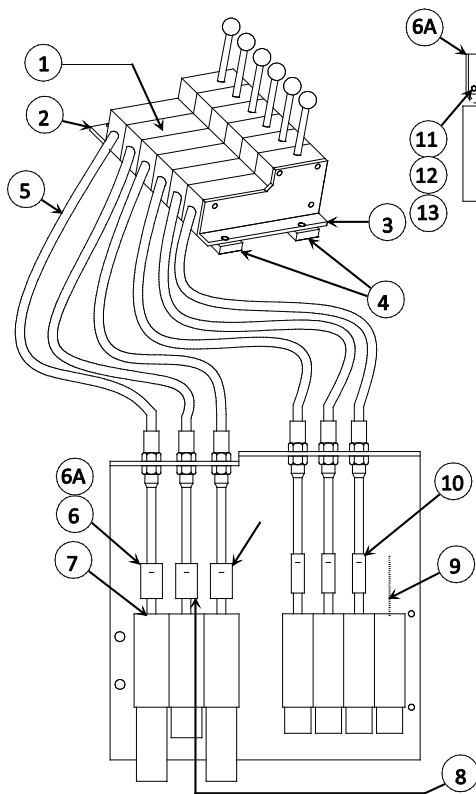

ITEM #	PART #	DESCRIPTION
1	11187	REMOTE CONTROL LEVER
2	10575	LH MOUNTING BRACKET
3	11163	RH MOUNTING BRACKET
4	12374	MOUNTING TABS
5		SEE TABLE BELOW
6A	114842	BRACKET ASSEMBLY – GRESSEN ONLY
6	114845	CABLE ADAPTER – FLOAT SPOOL – GRESSEN ONLY
7	10713	CLEVIS PIN
8	14998	PUSH ROD ADAPTER – FOR GRESSEN
	13441	PUSH ROD ADAPTER – FOR COMMERCIAL
9	119474	SHAKER STOP – GRESSEN ONLY
10	10629	PUSH ROD ADAPTER – GRESSEN ONLY
11	80002	BOLT
12	80500	NUT
13	80563	LOCK WASHER

CONTROL CABLE – MEASURE FROM END TO DETERMINE PART #	
118424	PUSH – PULL CABLE 45" LONG
10625	PUSH – PULL CABLE 65" LONG
14044	PUSH – PULL CABLE 72" LONG
13442	PUSH – PULL CABLE 96" LONG
113363	PUSH – PULL CABLE 108" LONG
113361	PUSH – PULL CABLE 126" LONG
116666	PUSH – PULL CABLE 130" LONG
113105	PUSH – PULL CABLE 148" LONG
116807	PUSH – PULL CABLE 150" LONG

Remote Control Levers

A set of remote control levers complete with cables are provided to control the plow directional control valve mounted on the plow's main mast. These levers should be located in a suitable position on the operator's right hand side. A set of mounting tabs are also provided with the levers and are to be welded to the tractor. The control cables are then hooked up to the plow directional valve and adjusted for proper shifting to the directional valve spools. These handles may be cut or bent for the comfort of the operator.

HYDRAULIC HOSE SPECIFICATION GUIDE

Flow Capacities of hose assemblies at suggested flow velocities.

HOSE SIZE	SPECIFICATIONS	USAGE
3/8, 1/2	SAE 100R2 OR SAE 100R2A	RECOMMENDED FOR PRESSURE LINES UP TO 2500 PSI
3/4	SAE 100R2A OR EQUIVALENT	
1, 1 1/4	SAE 100R9A 4 LIGHT SPIRAL WIRE OR EQUIVALENT	
1, 1 1/4	SAE 100R9A 4 LIGHT SPIRAL WIRE OR EQUIVALENT	
1, 1 1/4, 1 1/2, 2	SAE 100R4	RECOMMENDED FOR SUCTION LINES (MAY ALSO BE USED FOR LOW-PRESSURE RETURN LINES 100 PSI)

The chart on the next page is designed and provided as an aid in the determination of the correct hose size.

Example: At 13 Gallons per minute, what is the proper hose size within the suggested velocity range for pressure lines?

Solution: Locate 13 gallons per minute in the left hand column and 10 feet per second in the right hand column (the centre of the suggested velocity range for pressure lines). Lay a straight edge across these two points. The inside diameter required to give the desired velocity is the actual inside diameter shown in the centre column nearest the straightedge.

For suction hoses, follow the same procedure except use suggested velocity range for intake.

Based on formula:

$$\text{AREA (SQ. IN.)} = \frac{\text{G.P.M.} \times 0.3208}{\text{Velocity (FT/SEC)}}$$

** Suggestions are for oils having a maximum viscosity of 315 S S U at +100° F. (+38° C.) and operating at temperatures between +65° F. and + 155° F. (+54° C. to +69° C.). Under certain conditions velocities in pressure lines can be increased up to 25 feet per second.

FLOW U.S. GALLONS PER MINUTE

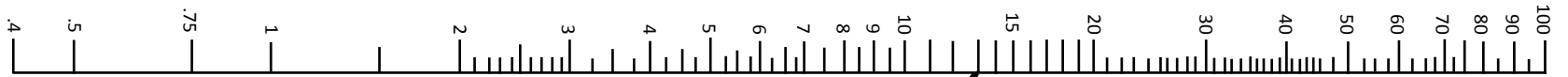

INSIDE DIAMETER OF HOSE, IN

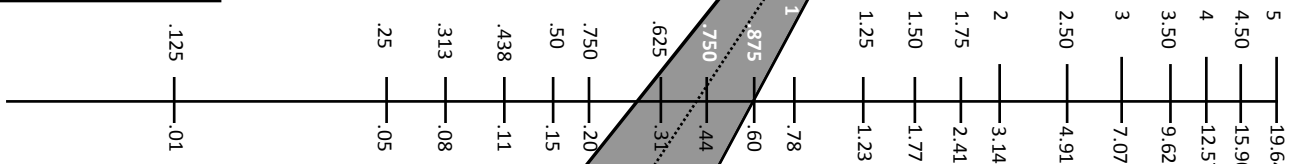

AREA IN SQ. IN.

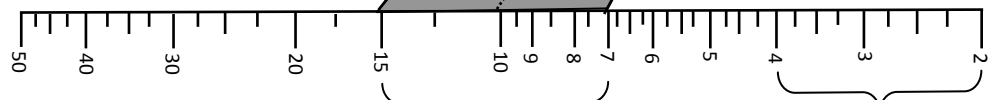

VELOCITY, FT. PER SEC.

SUGGESTED VELOCITY RANGE* FOR

SUGGESTED VELOCITY RANGE* FOR

PRE-OPERATION CHECKLIST

1. Prior to any movement of the plow functions, lubricate all points as per lubrication guide.
2. Ensure that all hydraulic lines, valves, etc. that may have been installed within the tractor cab are properly guarded to protect the operator in case of any hydraulic ruptures.
3. Check the hydraulic oil system to ensure that it is filled to the tractor manufacturer's specifications.
4. Prior to operation of hydraulics, ensure that no air is trapped in the circuit.
5. Start tractor and engage each function control of the plow and related accessories to ensure that the proper connections have been made and that there are no interference fits.
6. Check all hydraulic connections for leaks.
7. Check all fasteners to insure that they are properly torqued.
8. To protect hydraulic circuit and pump, line pressure must not exceed 2500 PSI. To set pressure at 2500 PSI:
 - a) Install pressure gauge in pressure line between tractor pump and directional control valve.
 - b) Activate main lift cylinder to raise plow to maximum position. **Hold** control lever open to build up line pressure.
 - c) Adjust relief setting in manifold inlet section of directional control valve to obtain 2500 PSI reading in the pressure gauge.

VIBRATORY PLOW OPERATION – VALVE SECTIONS

1) MAIN LIFT

This section controls the lift cylinder(s) and raises/lowers the plow assembly. This section also contains a float detent; float should only be used with tamper feet which work like skis. To place main lift cylinder into float, pull control lever hard towards operator. If directional control valve has been incorrectly mounted, in upside down position, then the float detent position will be in opposite direction. Operator preference and experience will determine ultimate use of float detent.

2) FRONT SWING

This section controls the two front swing cylinders connected to the backplate and main mast of the plow assembly. These cylinders activate the offsetting of the plow, right and left center. This section contains a float detent. To place front swing cylinder into float, pull the control lever hard towards operator. If directional control has been incorrectly mounted, in upside down position, then the float detent position will be in the opposite direction. Front swing cylinders should be in float during all plowing conditions. Operator preference and experience will determine ultimate use of the float detent.

3) REAR SWING

This section controls the parallel direction of the shank and chute. The shank and chute should be parallel to the tractor during plowing mode. If front swing cylinders are in float, the shank will always find the parallel position.

4) **ATTITUDE**

This section controls the angle or attitude of the shank. By angling the point of the shank towards the tractor, the shank will want to ride out of the ground. If the shank point is angled back away from the tractor, the shank will want to plow deeper into the ground. Once the plow depth has been achieved, the shank attitude should only be used to maintain desired depth.

5) **ADJUSTABLE BLADE LIFT**

This section raises and lowers the shank. When the directional valve section is in neutral, the shank is held in position with a double lock valve.

6) **SHAKER MOTOR**

The motor is omni-directional. A control cable is provided to the shaker motor flow control to control the speed of the shaker.

7) **POWER REWIND**

The half inch directional valve controls the direction of the power rewind wheel and the half inch flow divider controls the speed or the RPM. The hydraulic motor for the capstan and power rewind wheel requires 10 GPM max from the power source through speed control, to operate the motor and develop maximum of 96 wheel revolutions at full engine RPM. The speed control will regulate the wheel RPM from 0 (off) to maximum. Torque pressure of the wheel is 450 pounds at a maximum relief setting of 2000 PSI.

NOTE: Lubrication frequencies given below are minimums; the more you grease these points the longer your components will last.

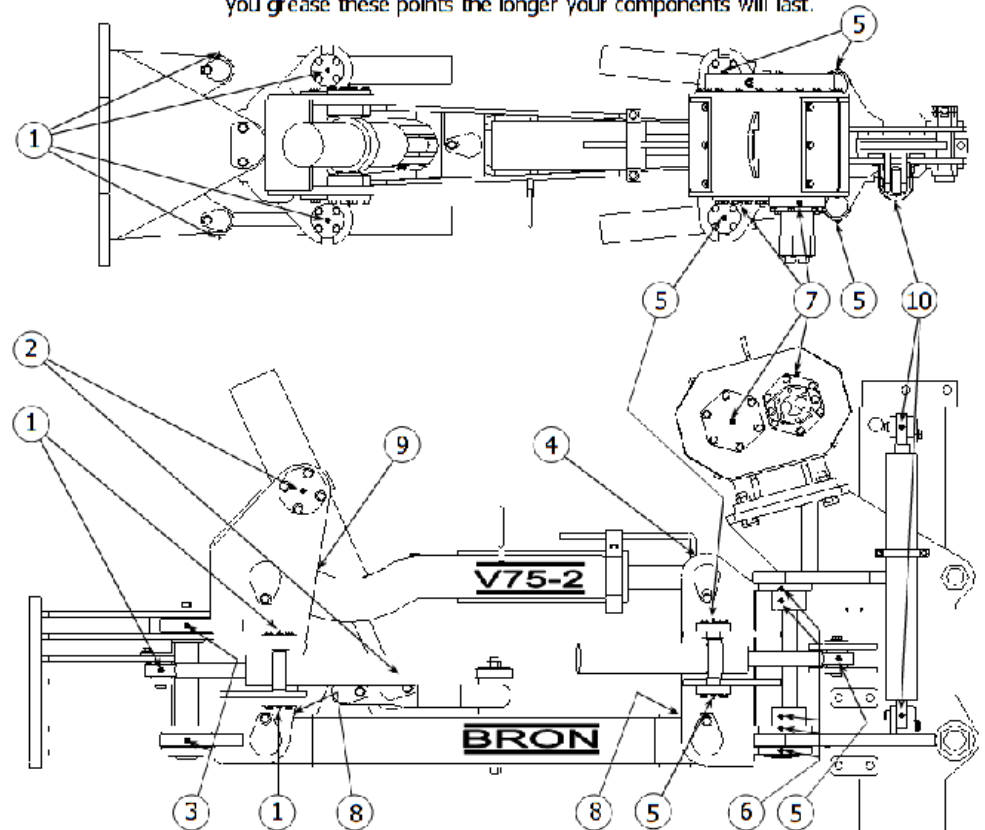

Location	Description	# of Points	Frequency
1	Front Swing Cylinders	6	twice daily
2	Main Lift Cylinder	3	twice daily
3	Front Mast	2	twice daily
4	Attitude Cylinder	1	twice daily
5	Rear Swing Cylinder	3	twice daily
6	Rear Mast	5	twice daily
7	Shaker Box	2	twice daily
8	Lower Link	4	twice daily
9	Upper Link	2	twice daily
10	Blade Lift Cylinder	2	twice daily



BRON V75-II PLOW WARRANTY

BASE WARRANTY (6 months or 600 hours):

RWF Industries a Division of Roberts Welding & Fabricating Ltd. (RWF) warrants that the new BRON **PLOW** sold by RWF will be free from defects in material or workmanship for a period of 6 months or 600 operating hours, whichever occurs first, starting from the date of delivery to the first user.

THIS WARRANTY DOES NOT APPLY TO:

HYDRAULIC and MOUNTING INSTALLATION KIT PARTS, HOSES, OR REPLACEMENT PARTS, which are covered by other warranties

RWF RESPONSIBILITY:

RWF will, at its option, repair or replace with a new or reconditioned part, any warranted part that fails by reason of defective material or workmanship, free of charge delivered at a place of business of an RWF Dealer. Note: parts replaced under warranty become the property of RWF. During the 6 month or 600 hour BASE WARRANTY period, RWF will pay the reasonable cost of labor that is necessary to install any repaired or replacement part during normal working hours. Overtime rates and travel expenses will not be reimbursed.

USER RESPONSIBILITY:

- The installer, operator, or service person, assumes responsibility to read, understand and comply with RWF's written INSTALLATION, OPERATOR, SERVICE AND WELDING INSTRUCTIONS
- All costs associated with transporting the attachment and/or equipment to an authorized location.
- RWF is not responsible for any expense incurred in field repair.

THESE WARRANTIES DO NOT COVER FAILURES RESULTING FROM:

- Installation, alteration, operation, maintenance, repair or storage which RWF judges improper.
- Not performing DAILY VISUAL INSPECTIONS AND RETIGHTENING as specified in RWF Manuals.
- Not following RWF's recommended welding procedure.
- Operation after discovery of defective or worn parts.
- Unreasonable delay in making a repair after being notified of a potential problem.
- Acts of God, war, vandalism, riot, theft, explosion, and any other act of nature or man

THESE WARRANTIES SPECIFICALLY EXCLUDE:

- Installations not approved by RWF.
- Hardface welding to build up wear on surfaces.
- Replacement due to wear.
- Ground engaging tools. Points, guards, blades etc
- Repairs by other than an authorized RWF Dealer.
- Any alteration to BRON products.
- Use of parts not sold by RWF.
- Labor charges deemed excessive by RWF.
- Parts shipping charges in excess of those, which are usual and customary.
- Duty and local taxes.

LIMITATIONS AND EXCLUSIONS:

Violation of any federal, provincial, state or local laws, ordinances, rules or regulations, or removal or alteration of product serial numbers void RWF's written product warranties. The written product warranties made by RWF set forth RWF's only obligations with respect to any claims of failure, defects or deficiencies in products sold by RWF. RWF MAKES NO OTHER WARRANTIES OR REPRESENTATIONS WHATSOEVER, EXPRESS OR IMPLIED, OF THE QUALITY, PERFORMANCE, DURABILITY, MATERIALS, WORKMANSHIP, SUITABILITY, CONDITION, DESIGN OR UTILITY OF PRODUCTS SOLD BY RWF, INCLUDING, WITHOUT LIMITATION, IMPLIED WARRANTIES OR MERCHANT ABILITY AND FITNESS. ALL SUCH OTHER WARRANTIES AND REPRESENTATIONS BEING HEREBY EXPRESSLY EXCLUDED. RWF SHALL NOT BE LIABLE FOR SPECIAL INCIDENTAL OR CONSEQUENTIAL DAMAGES INCLUDING WITHOUT LIMITATION, COSTS, LOSSES, OR LIABILITIES ON ACCOUNT OF DELAY OR DOWNTIME.

DISCLAIMER REGARDING OTHER REPRESENTATIONS OR WARRANTIES:

No person is authorized to grant any other warranties or to assume any other liability on RWF's behalf unless made or assumed in writing by an officer of RWF. No person to grant any warranties or to assume any liabilities on the seller's behalf unless made or assumed in writing by the seller. As used in this warranty the term RWF means, RWF Industries, a division of Roberts Welding and Fabricating Ltd, Woodstock, Ontario, Canada.

SOME ITEMS NOT COVERED BY WARRANTY:

Items and service related functions that are not covered by warranty include, but are not limited to:

- Issues resulting from misuse, negligence or accident.
- Issues arising from the use of non-approved parts.
- Repair or adjustment by other than RWF or its authorized dealers.
- Issues resulting from the installation of unauthorized attachments or modifications.
- Tightening of nuts, bolts, screws, etc. or adjustments.
- Natural wear or defects caused by natural wear.
- Issues due to use of improper oil, grease, or other lubricant.
- Daily allowances and overtime labor rates.
- Indirect damages such as loss of earning, etc.
- Normal maintenance services. Maintenance services not directly involved with defective parts are considered normal service and should be excluded from a claim.